



# City Of Boca Raton

## Municipal Services/Engineering Division

201 West Palmetto Park Road, Boca Raton Florida 33432-3795

### Traffic Calming New Pines South Sidewalk Improvements SW 15th Street and SW 17th Street Workorder #11

**DRAWING INDEX**

SHEET No.	SHEET DESCRIPTION
1	Cover Sheet
2	Speed Hump Location Sheet
3	Speed Hump Notes and Details
4	ADA Sidewalk Improvements Location Sheet
5	Sidewalk Details



**PROJECT LOCATION  
(SPEED HUMPS)**

**PROJECT LOCATION  
(SIDEWALKS)**

THIS PLANS HAVE BEEN PREPARED IN ACCORDANCE WITH AND ARE GOVERNED BY THE STATE OF FLORIDA DEPARTMENT OF TRANSPORTATION, ROADWAY AND TRAFFIC DESIGN STANDARDS. (BOOKLET DATED JANUARY 2010), AND INTERIM STANDARDS

ATTENTION IS DIRECTED TO THE FACT THAT THESE PLANS MAY HAVE BEEN ALTERED IN SIZE BY REPRODUCTION. THIS MUST BE CONSIDERED WHEN OBTAINING SCALED DATA.

GOVERNING SPECIFICATIONS: STATE OF FLORIDA DEPARTMENT OF TRANSPORTATION, STANDARD SPECIFICATIONS, DATED 2004 AND SUPPLEMENTAL SPECIFICATIONS.

THE ATTACHED IS AN AUTOCAD FILE OF THE ABOVE REFERENCED PROJECT. USING THE FILES IN ANY MANNER INDICATES YOUR ACCEPTANCE OF TERMS AND CONDITIONS AS SET FORTH BELOW. IF YOU DO NOT AGREE TO ALL OF THE TERMS AND CONDITIONS, PLEASE CONTACT OUR OFFICE PRIOR TO ANY USE OF THE REFERENCED INFORMATION.

PLEASE BE ADVISED THAT THE ATTACHED FILE IS IN A FORMAT THAT CAN BE ALTERED BY THE USER. DUE TO THIS FACT, ANY REUSE OF THE DATA WILL BE AT THE USER'S SOLE RISK WITHOUT LIABILITY OR LEGAL EXPOSURE TO THE CITY OF BOCA RATON, AND USER SHALL INDEMNIFY AND HOLD HARMLESS THE CITY OF BOCA RATON, FROM ALL CLAIMS, DAMAGES, LOSSES AND EXPENSES INCLUDING ATTORNEY'S FEES ARISING OUR OF OR RESULTING FROM USING THE DIGITAL FILE.

IN ADDITION, IT IS THE RESPONSIBILITY OF THE USER TO COMPARE ALL DATA WITH THE SIGNED AND SEALED SURVEY(S). IN THE EVENT THERE IS A CONFLICT BETWEEN THE SIGNED AND SEALED SURVEY(S) AND THE ELECTRONIC FILE, THE SIGNED AND SEALED SURVEY(S) SHALL PREVAIL. THE TRANSMISSION OF THIS DIGITAL FILE DOES NOT CONSTITUTE A WAIVER OF THE OWNERSHIP RIGHTS OF THE CITY OF BOCA RATON. THIS DIGITAL FILE SHOULD NOT BE REPRODUCED OR COPIED WITHOUT WRITTEN PERMISSION.

IF YOU HAVE ANY QUESTIONS, PLEASE DO NOT HESITATE TO CONTACT THE ENGINEERING DIVISION FOR THE CITY OF BOCA RATON.

No.	Revision	By:	Date:

**(ATTACHMENT "A")**

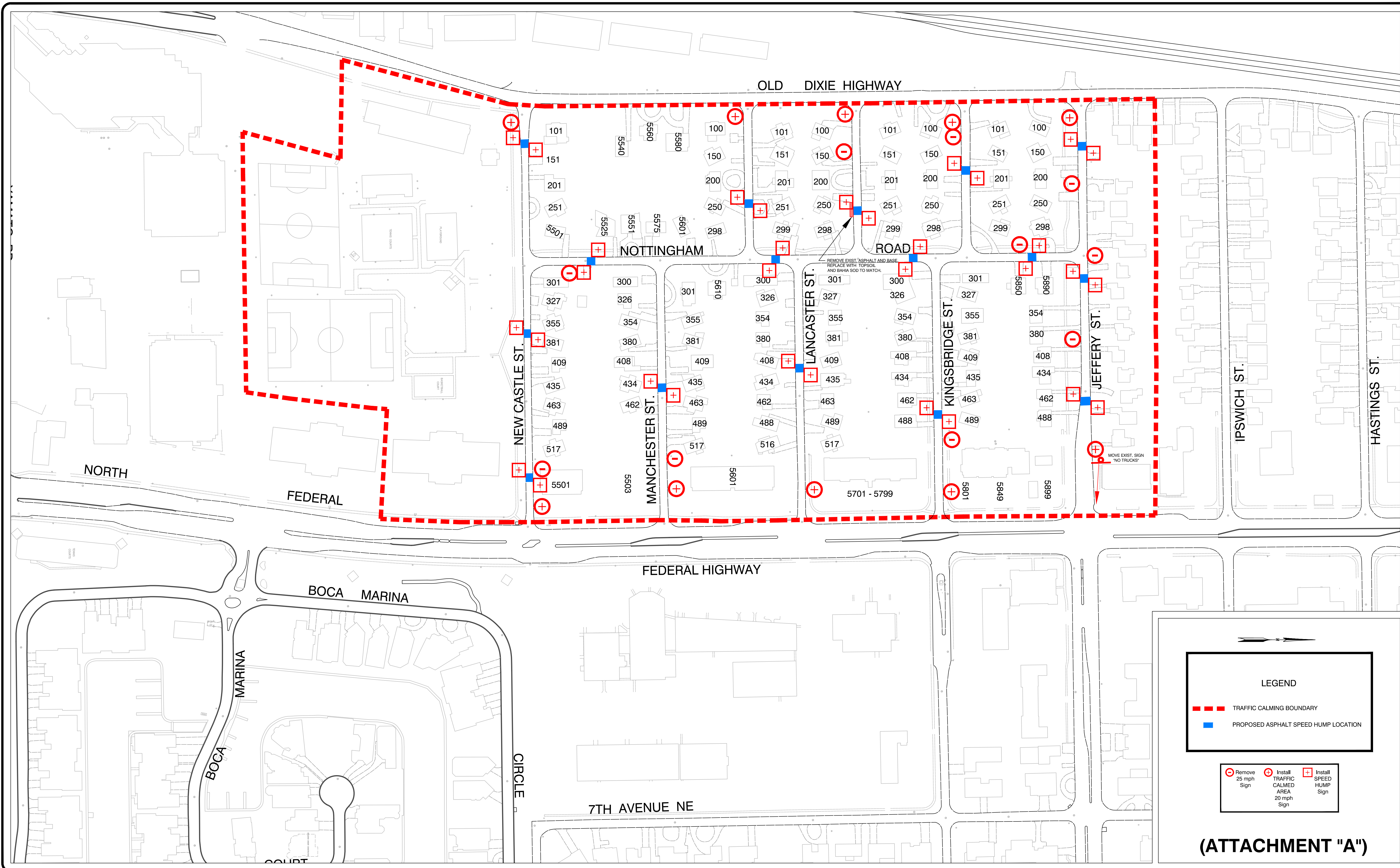

**LEGEND**

- - - TRAFFIC CALMING BOUNDARY  
■ PROPOSED ASPHALT SPEED HUMPS LOCATION

Remove 25 mph Sign	Install TRAFFIC CALMED AREA 20 mph Sign	Install SPEED HUMPS Sign
--------------------	---	--------------------------

**(ATTACHMENT "A")**

**City Of Boca Raton**

**Municipal Services/Engineering Division**

201 West Palmetto Park Road, Boca Raton Florida 33432-3795 Tel. (561)416-3401

No.	Revision	By:	Date:

Scale: 1"=100'  
 Drawn By: A.B.  
 Checked By: S.P.  
 Approved By: S.P.  
 Drawing Date: 2/12/2004  
 Field Book#: .  
 Page#: .

- Issued For :
- Permits
  - Bidding
  - Review & Comments
  - Construction
  - Informational

**Traffic Calming**  
**New Pines South**  
**Speed Hump Locations**

Drawing No. T-505  
 Project No.  
 SHEET  
**2 OF 5**

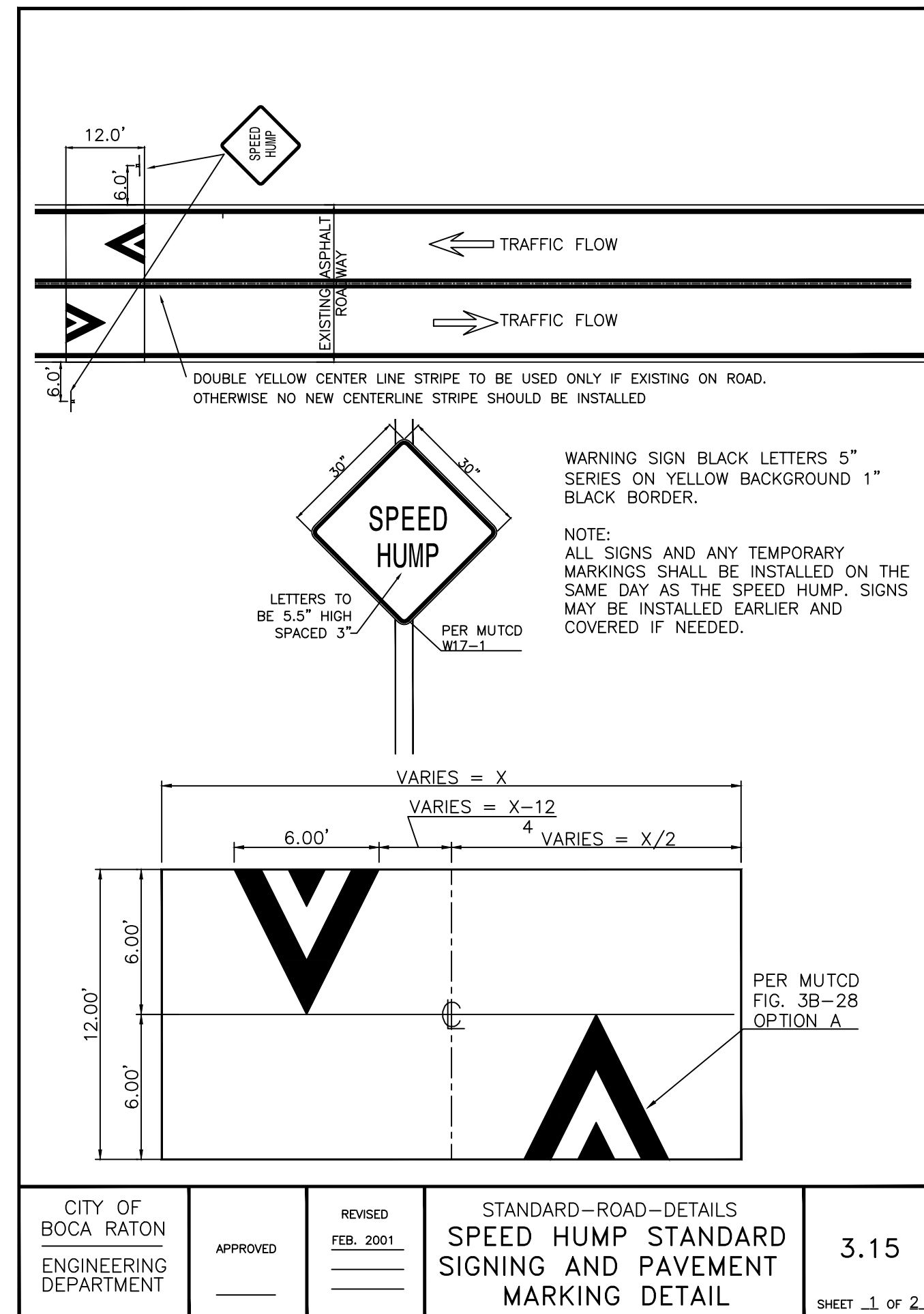

SP-29

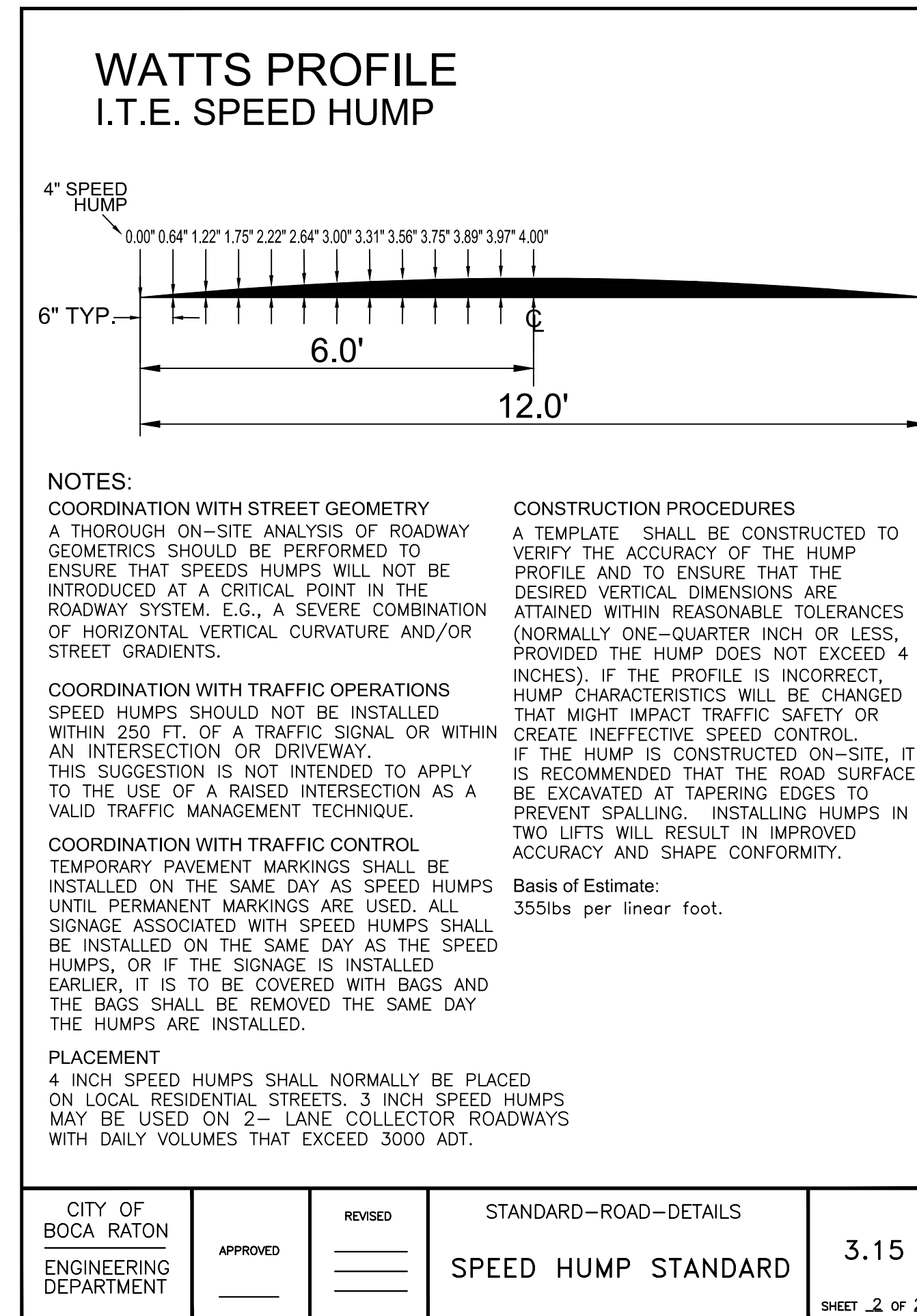

SP-30

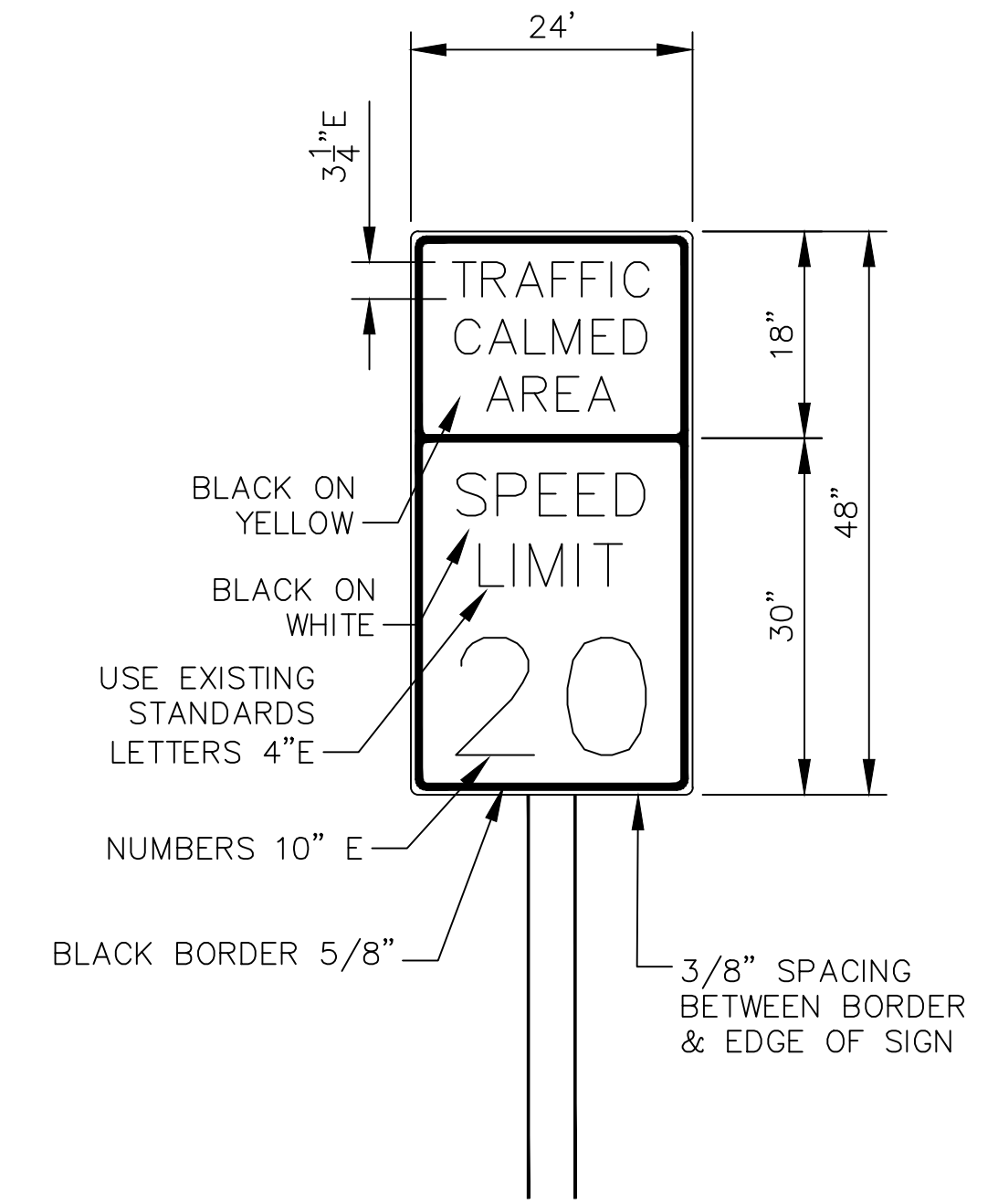

SPECIAL TRAFFIC CALMED AREA SIGNS

MAINTENANCE OF TRAFFIC NOTES

- THE CONTRACTOR IS REQUIRED TO MAINTAIN PEDESTRIAN AND VEHICULAR TRAFFIC ON THIS PROJECT. THE FLORIDA DEPARTMENT OF TRANSPORTATION STANDARD INDEX DRAWINGS NOS. 600 THROUGH 660 AND THE MANUAL OF UNIFORM TRAFFIC CONTROL DEVICES AND SUBSEQUENT ADDENDUM AND REVISIONS SHALL SET FORTH THE MINIMUM STANDARDS FOR THE INSTALLATION, MAINTENANCE AND SUBSEQUENT REMOVAL OF ALL CONSTRUCTION SIGNS, DETOURS, STREET CLOSINGS, FLASHING ARROW BOARDS FOR LANE DROPS, ANY TEMPORARY PAVEMENT, WORK ZONE PAVEMENT MARKINGS, BARRICADES AND WARNING LIGHTS AS MAY BE NEEDED TO MAINTAIN VEHICLE AND PEDESTRIAN TRAFFIC.
- THE CONTRACTOR SHALL PREPARE AND SUBMIT FOR REVIEW AND APPROVAL, MAINTENANCE OF TRAFFIC PLAN FOR EACH PHASE OF CONSTRUCTION IN ACCORDANCE WITH SECTION 102 OF THE FDOT SPECIFICATIONS.

(ATTACHMENT "A")



City Of Boca Raton  
Municipal Services/Engineering Division

201 West Palmetto Park Road, Boca Raton Florida 33432-3795 Tel. (561)416-3401

No.	Revision	By:	Date:

Scale: .  
Drawn By: .  
Checked By: .  
Approved By: .  
Drawing Date: .  
Field Book#: .  
Page#: .

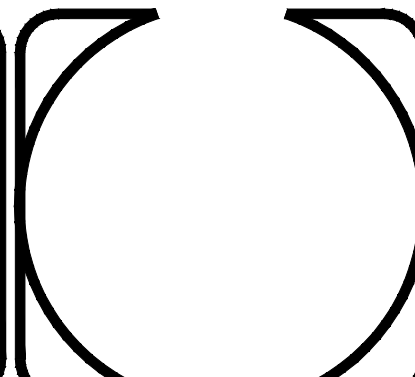

Issued For :  
 Permits  
 Bidding  
 Review & Comments  
 Construction  
 Informational

**Traffic Calming  
Asphalt Speed Hump Details  
New Pines South**

Drawing No. T-505  
Project No. .  
SHEET  
**3 OF 5**

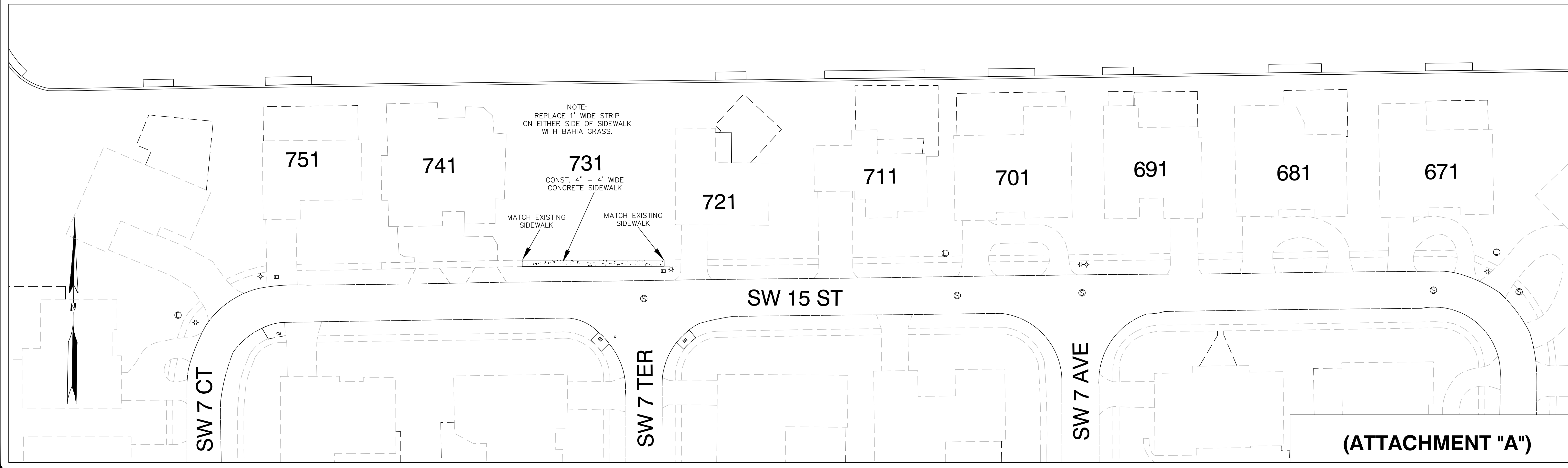
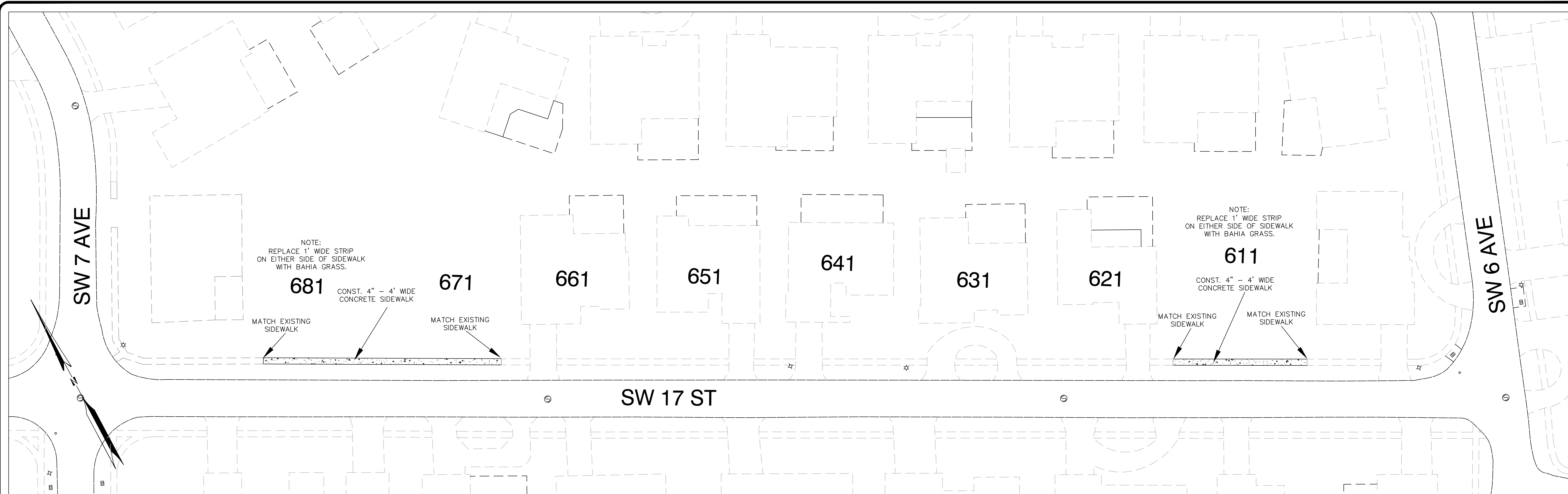

**(ATTACHMENT "A")**



**City Of Boca Raton**  
**Municipal Services/Engineering Division**

201 West Palmetto Park Road, Boca Raton Florida 33432-3795 Tel. (561)416-3401

No.	Revision	By:	Date:

Scale: 1"=30'  
 Drawn By: A.B.  
 Checked By: S.P.  
 Approved By: S.P.  
 Drawing Date: 2/12/2004  
 Field Book#: .  
 Page#: .

- Issued For :
- Permits
  - Bidding
  - Review & Comments
  - Construction
  - Informational

**ADA Sidewalk Improvements**  
**Location Sheet**  
**SW 15th Street & SW 17th Street**

Drawing No. T-505  
 Project No.  
 SHEET  
**4 OF 5**

TYPICAL SIDEWALK DETAIL  
N.T.S.

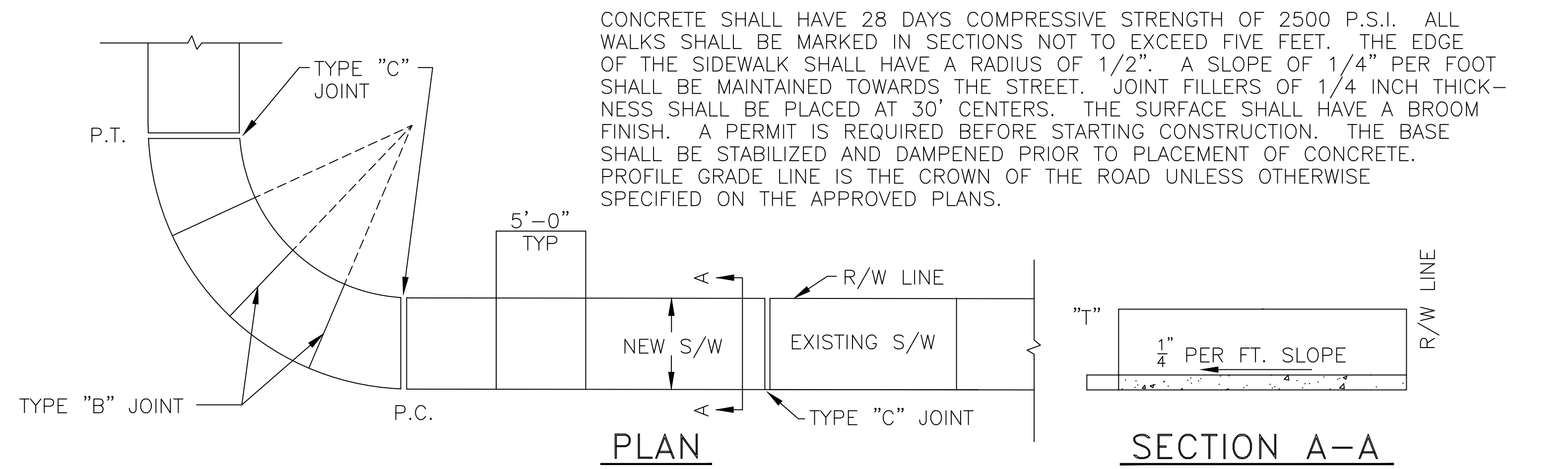

CONCRETE SHALL HAVE 28 DAYS COMPRESSIVE STRENGTH OF 2500 P.S.I. ALL WALKS SHALL BE MARKED IN SECTIONS NOT TO EXCEED FIVE FEET. THE EDGE OF THE SIDEWALK SHALL HAVE A RADIUS OF 1/2". A SLOPE OF 1/4" PER FOOT SHALL BE MAINTAINED TOWARDS THE STREET. JOINT FILLERS OF 1/4 INCH THICKNESS SHALL BE PLACED AT 30' CENTERS. THE SURFACE SHALL HAVE A BROOM FINISH. A PERMIT IS REQUIRED BEFORE STARTING CONSTRUCTION. THE BASE SHALL BE STABILIZED AND DAMPENED PRIOR TO PLACEMENT OF CONCRETE. PROFILE GRADE LINE IS THE CROWN OF THE ROAD UNLESS OTHERWISE SPECIFIED ON THE APPROVED PLANS.

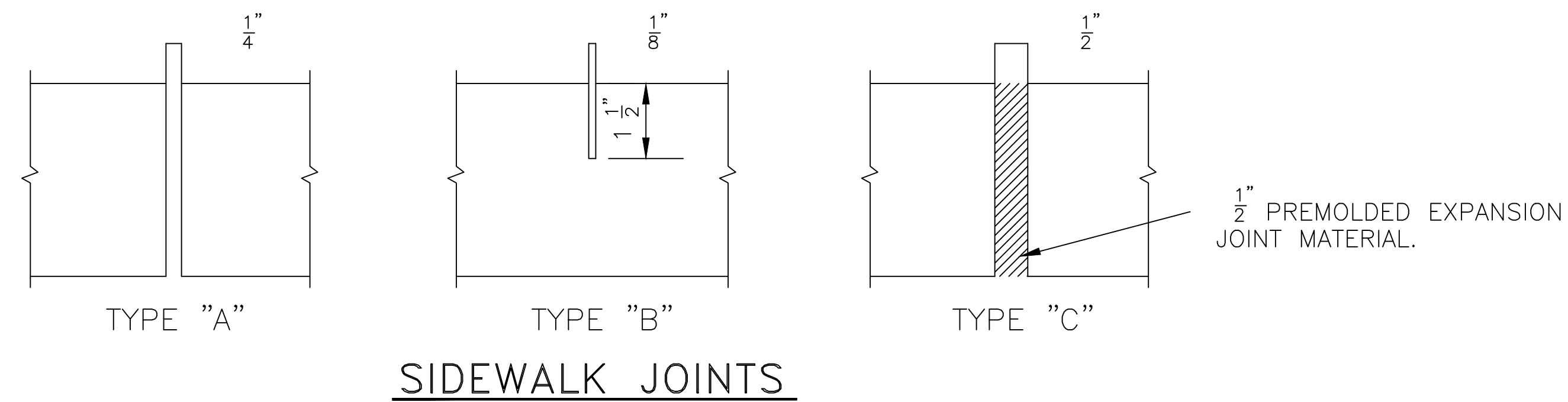

TABLE OF SIDEWALK THICKNESS — "T"	
LOCATION	"T"
OTHER	4"
AT DRIVEWAYS & 5' EITHER SIDE	6"

TABLE OF SIDEWALK JOINTS	
TYPE	LOCATION
"A"	P.C. AND P.T. OF CURVES JUNCTION OF EXISTING AND OF NEW SIDEWALK.
"B"	5'-0" CENTER TO CENTER ON SIDEWALK.
"C"	WHERE SIDEWALK ABUTS CONCRETE CURBS, DRIVEWAYS, AND SIMILAR STRUCTURES.

**(ATTACHMENT "A")**



**City Of Boca Raton**  
**Municipal Services/Engineering Division**

201 West Palmetto Park Road, Boca Raton Florida 33432-3795 Tel. (561)416-3401

No.	Revision	By:	Date:

Scale: N.T.S.  
 Drawn By: A.W.B.  
 Checked By: J.T.P.  
 Approved By: J.T.P.  
 Drawing Date: 9/20/2010  
 Field Book#: .  
 Page#: .

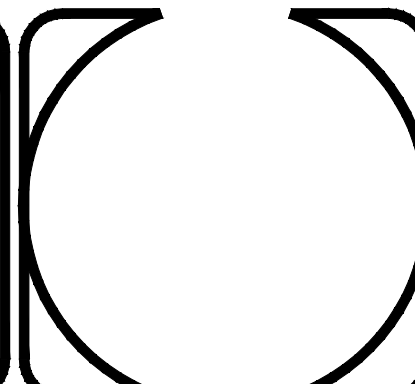

- Issued For :
- Permits
  - Bidding
  - Review & Comments
  - Construction
  - Informational

**ADA Sidewalk Improvements**  
**Notes & Details**  
**SW 15th Street & SW 17th Street**

Drawing No. T-505  
 Project No.  
 SHEET  
**5 OF 5**